

UFP	A		B min.		H		L2		R		S		K	
	mm	inch	mm	inch	mm	inch	mm	inch	mm	inch	mm	inch	mm	inch
STANDARD	M5 x 0.8		12.5	.492	8.5	.335	47.5	1.870	6.1	.240	3.0	.118	34.0	1.339
LARGE	M8 x 1.25		24.6	.969	18.0	.709	98.0	3.858	10.1	.398	3.0	.118	63.0	2.480
UFP	G		T		U dia		V		J min.		E		M	
	mm	inch	mm	inch	mm	inch	mm	inch	mm	inch	mm	inch	mm	inch
STANDARD	M5 x 0.8		1.0	.039	6.0	.236	4.0	.157	5.0	.197	13.5	.531	6.1	0.240
LARGE	M10 x 1.5		1.4	.055	11.0	.433	8.0	.315	10.0	.394	32.0	1.260	10.0	.394

STYLE	'F' DIMENSION	INSERT
UFP 0390	16.00 (0.063)	WCGX 030204
UFP 0690	16.00 (0.063)	CC..060204
UFP 0695	16.00 (0.063)	CC..060204
UFP 1190	20.00 (0.787)	TC..110204
UFP 0690BB	20.00 (0.787)	CC..060204
UFP 07120	16.00 (0.063)	DC..070204

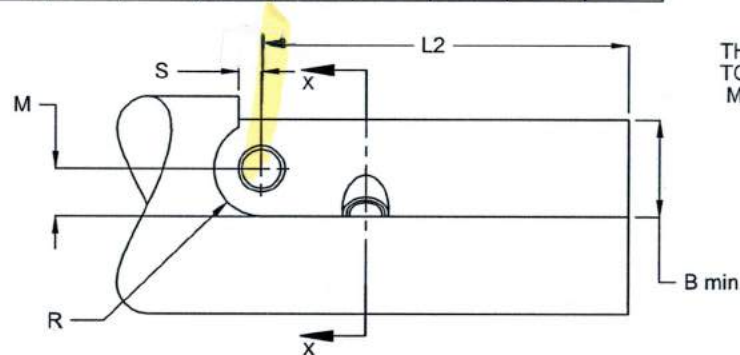
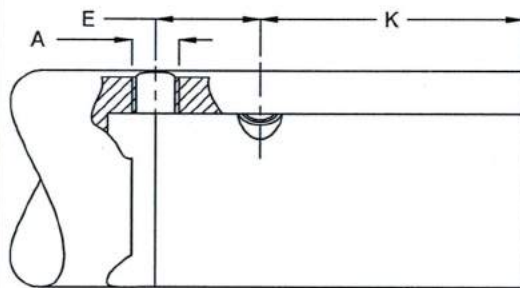

THE UFP CARTRIDGE IS PRE-TENSIONED AT ITS NOMINAL 'F' DIMENSION. TO ENSURE RIGIDITY OF THE CUTTING EDGE THE DEPTH OF THE POCKET MUST BE CALCULATED BY 'F' + 0.05mm FROM THE CUTTING DIAMETER

PLEASE NOTE THE FLUTE ORIENTATION. THE FLUTE START POINT IS 4.5mm FROM THE INSERT ('H'). THE FLUTE REQUIRES A HEIGHT OF 1mm BELOW THE CARTRIDGE POCKET. ('F' + 0.05mm + 1mm). THIS WILL ENABLE SUCCESSFUL CHIP EXTRACTION.

Ø3.00  
COOLANT FEED HOLE  
DRILLED IN THIS AREA  
\*NOT SMARTBORE

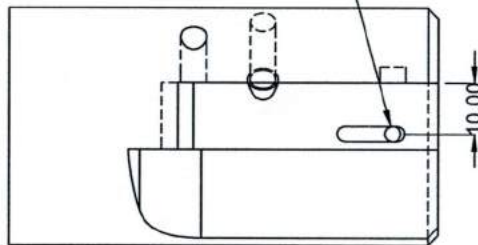

UFP 0690

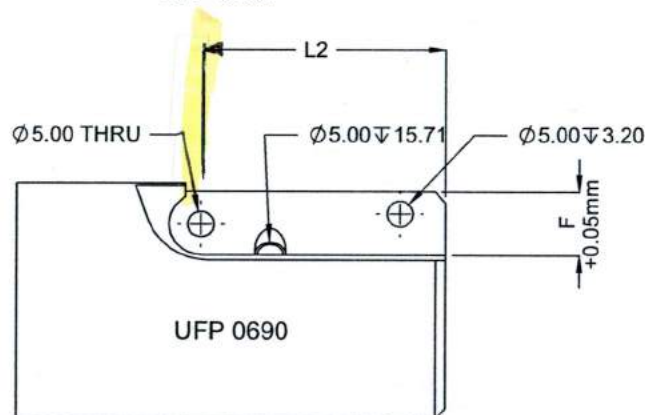
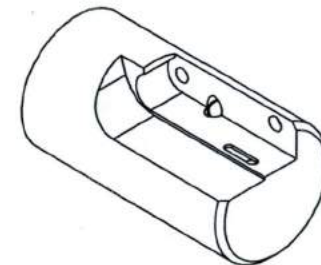
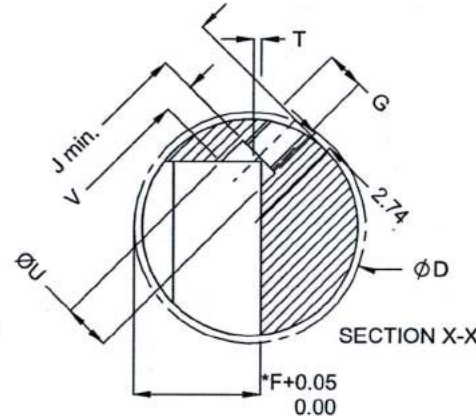

UFP 0690

4.5mm DISTANCE FROM INSERT FACE TO FLUTE  
'H' DISTANCE FROM CARTRIDGE TIP TO POCKET FACE  
SEE SKETCH A

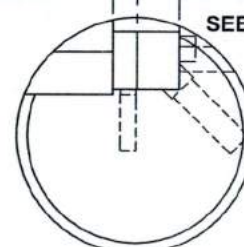

SKETCH A

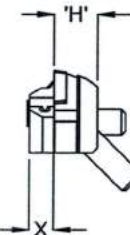

X CORRESPONDS TO THE START POINT OF THE FLUTE. THIS WILL BE 4.5mm.

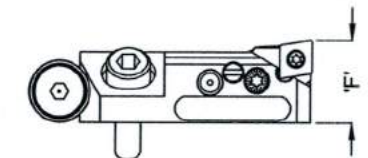

MODEL DETAILING 'F' DIMENSION

MATERIAL:	DRAWN BY:	DATE:	DESCRIPTION:
		31/05/2012	SMARTBORE AND UFP MOUNTING SHEET
CONDITION:	CHECKED BY:	DATE:	PART NO:
		31/05/2012	
TOLERANCES UNLESS OTHERWISE STATED:	SIZE:	APPROVED BY:	DATE:
1. LINEAR TOLERANCES ± 0.1	A3		31/05/2012
2. SURFACE ROUGHNESS MAX	SCALE:	SHEET:	
	1:1	1 OF 1	
DIMENSIONS IN MILLIMETERS			

OSLIFORD ROAD INDUSTRIAL  
ESTATE, HAYLE, CORNWALL, TR27 4BA,  
UK  
TEL: +44(0)1750 75355  
EMAIL: RIGIB@RIGIB.COM  
DRAWINGS REMAIN THE PROPERTY OF  
RIGIBORE LTD. NOT TO BE REPRODUCED  
OR USED FOR ANY OTHER PURPOSE  
EXCEPT AS AUTHORIZED IN WRITING.