

# Cartridges

High precision fine boring and roughing

**Product range**

- UFP with zero backlash
- Smartbore with zero backlash
- ISO
- Roughing

Rigibore® The Most Accurately Adjustable Boring Tools in the World

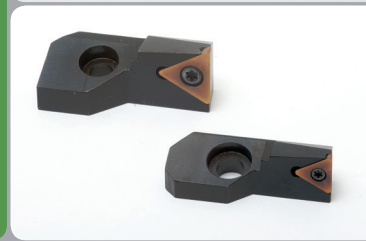
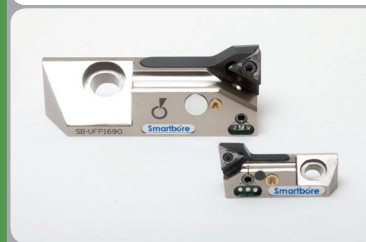

## Smartbore Cartridges

Supports high precision finishing and semi-finishing applications; offers a more accurate method of adjustment on the machine spindle

Use the Smartbore adjuster to plug in to the Smartbore cartridge, rotate the adjuster handle to make your adjustment and retract from cartridge

Accurate to just 1 micron; fast, easy adjustment using our digital torx wrench

**Easy and accurate adjustment**  
Reduces time presetting

**Single or multi point cartridge systems**  
Feature any number of Smartbore cartridges per tool

**Easily replaceable cartridges**  
If the cartridge gets damaged you just replace the cartridge and not the complete tool!

**Excellent repeatability and rigidity**  
A consistent preload maintains accuracy in the toughest of applications

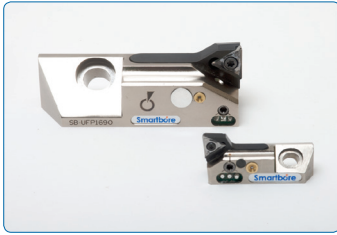

\* Minimum bore: 28mm (cartridge) 16mm (built-in)

### Smartbore Cartridges Technical Specification

	Part Number	D (Min Bore $\phi$ )		f		L1		Insert	Datum Rad	
		mm	inch	mm	inch	mm	inch		mm	inch
<p><b>SB-UIP0695</b></p>	SB-UIP0695 SB-UIP0695LH	28.0	1.102	16.0	0.630	55.5	2.185	CC..0602..	0.4	0.016
<p><b>SB-UIP07120</b></p>	SB-UIP07120 SB-UIP07120LH	28.0	1.102	16.0	0.630	58.5	2.303	DC..0702..	0.4	0.016
<p><b>SB-UIP1195</b></p>	SB-UIP1195 SB-UIP1195LH	36.0	1.417	20.0	0.787	55.5	2.185	TC..1102..	0.4	0.016
<p><b>SB-UIP0695</b></p>	SB-UIP1290	75.0	2.953	32.0	1.260	107.0	4.213	CC..1204..	0.8	0.031
<p><b>SB-UIP1195</b></p>	SB-UIP1690	75.0	2.953	32.0	1.260	107.0	4.213	TC..16T3..	0.8	0.031

## Smartbore Cartridges Technical Specification

**Right hand** - Shown  
**Left hand** - Mirror image

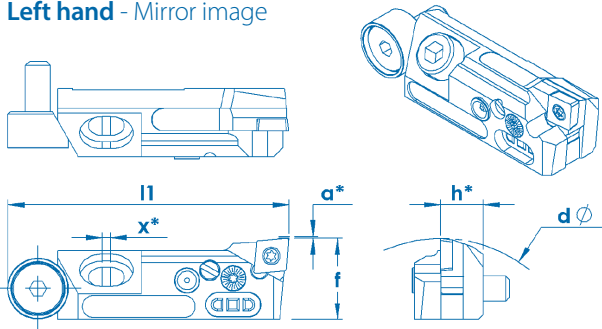

**a\*** - 0.3 adjustment on all UFP's, adjustment = 0.001mm per division on diameter

**h\*** - 8.5 on SB-UFP 06-11

**h\*** - 18.0 on SB-UFP 12-16

**x\*** - 1.0 on SB-UFP 06-11

**x\*** - 1.6 on SB-UFP 12-16

## Smartbore & UFP Cartridges Mounting Dimensions

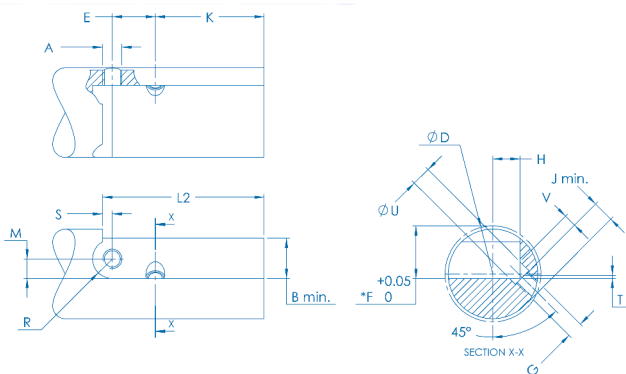

No machine spindle modification required. Smartbore bars can be carried in a standard magazine and tool management system.

Smartbore cartridges are easily replaceable.

UFP	A	B (min)		H		L2		R		S		K	
	metric	mm	inch	mm	inch	mm	inch	mm	inch	mm	inch	mm	inch
<b>Standard</b>	M5 x 0.8	12.5	0.492	8.5	0.334	47.5	1.870	6.1	0.240	3.0	0.118	34.0	1.338
<b>Large</b>	M8 x 1.25	24.6	0.968	18.0	0.708	98.0	3.858	10.1	0.397	3.0	0.118	63.0	2.480

  

UFP	G	T		U (diam.)		V		J (min)		E		M	
	metric	mm	inch	mm	inch	mm	inch	mm	inch	mm	inch	mm	inch
<b>Standard</b>	M5 x 0.8	1.0	0.039	6.0	0.236	4.0	0.157	5.0	0.196	13.5	0.531	6.1	0.240
<b>Large</b>	M10 x 1.5	1.4	0.055	11.0	0.433	8.0	0.314	10.0	0.393	32.0	1.259	10.0	0.393

## Smartbore Cartridges Spares and Accessories

UFP	Clamp Screw	Hexagon Wrench for Clamp Screw	Axial Adjusting Screw	Axial Wedge	Insert Screw	Torx Wrench for Insert Screw	Grease Gun	Hexagon Wrench for Axial Screw	Torx Wrench for Adjustment Screw
<b>Standard</b>	WS360	R58	WS359	WP311	RS2560	R37	UFPG_00	R48	R57 (T10)
<b>Large (1290, 1690)</b>	WS1035	R108	WS830	WP411	RS40120	R87 R77		R88	

## Smartbore Cartridge Technical Information

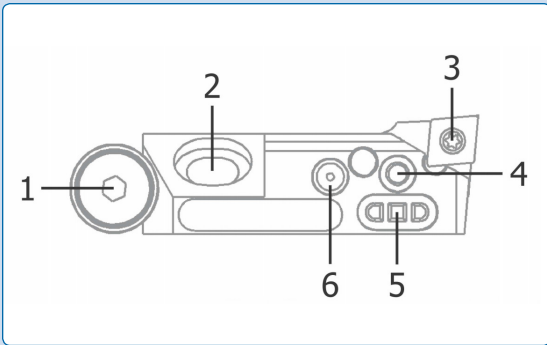

1. **Axial adjustment (1 mm) by wedge component**  
(Use screw/wedge WS359/WP311)
2. **Use clamping screw WS360 (5-6 Nm)**
3. **Use insert screw RS2560 (RS2055 for WC insert)**
4. **Micron adjustment (use Smartbore adjuster)**  
0.001 mm on diameter  
Radial adjustment 0.3 mm
5. **Smartbore electronic interface**  
The internal electronic transducer is activated when the Smartbore adjuster is connected
6. **Lubrication point**  
Lubrication with a high quality teflon based grease should be used in accordance with the maintenance schedule overleaf.

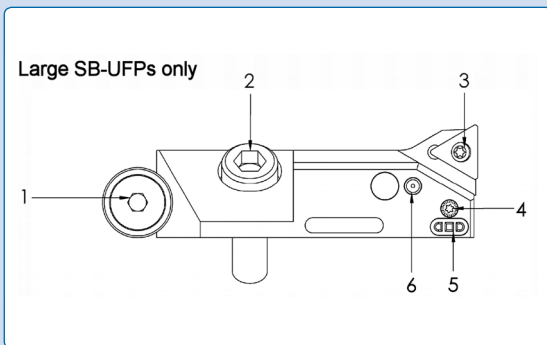

1. **Axial adjustment (1 mm) by wedge component**  
(Use screw/wedge WS830/WP411)
2. **Use clamping screw WS1035**
3. **Use insert screw RS4084 (RS40120 for CC12)**
4. **Micron adjustment (use Smartbore adjuster)**  
0.001 mm on diameter  
Radial adjustment 0.3 mm
5. **Smartbore electronic interface**  
The internal electronic transducer is activated when the Smartbore adjuster is connected
6. **Lubrication point**  
Lubrication with a high quality teflon based grease should be used in accordance with the maintenance schedule overleaf.

## Smartbore & ActiveEdge Cartridge Maintenance

ActiveEdge and Smartbore cartridges require regular maintenance to ensure optimal performance and durability, especially when machining cast iron.

The greasing process is designed to flush out small chips and machining dust that may build up in the cartridge mechanism. Grease should be pumped into the cartridge until it emerges clean from around the slide.



### Recommended Greasing Intervals

Material/Usage	Heavy	Medium	Light
<b>Ferrous (cast iron) - no coolant</b>	3/week	2/week	1/week
<b>Ferrous (cast iron)</b>	2/week	1/week	1/week
<b>Ferrous (steel)</b>	1/week	1-2 weeks	1/month
<b>Non-ferrous</b>	1-2 weeks	1/month	6/year

The correct operation and micron accuracy of the adjustment will be negatively affected unless the above schedule is adhered to

## UFP Cartridges

A wide range of adjustable cartridges for finish boring

Ideal for productivity situations where close tolerances on sizes are required. Features include fine graduations and interchangeable components

Accurate, ultra-fine precision cartridges

### Fine tolerance adjustment

Rigibore UFP Cartridges feature zero backlash and are graduated to 5 microns/0.0002" per division on diameter over a range of 0.6mm/0.024".

### Axial Positional Adjustment for length tolerances

Special tools are easily adjusted to extremely high levels of accuracy.

### Outstanding value

Maintaining close tolerances more consistently over longer periods of time means productivity increases significantly.

Available for 'heavy' duty finishing



### UFP Cartridge Technical Data

	Part Number	D (min bore Ø)		f		L1		Insert	Datum Rad	
		mm	inch	mm	inch	mm	inch		mm	inch
	UFP-0390 UFP-0390LH	28.0	1.102	16.0	0.629	55.5	2.185	WCGX 03 02 ..	0.4	0.016
	UFP-0690 UFP-0690LH	28.0	1.102	16.0	0.629	55.5	2.185	CC or CP 06 02 ..	0.4	0.016
	UFP-0695 UFP-0695LH	28.0	1.102	16.0	0.629	55.5	2.185	CC or CP 06 02 ..	0.4	0.016
	UFP-0690BB	36.0	1.417	20.0	0.787	46.0	1.811	CC or CP 06 02 ..	0.4	0.016
	UFP-07120 UFP-07120LH	36.0	1.417	16.0	0.629	58.5	2.303	DC 07 02 ..	0.4	0.016

Continued...

Continued...

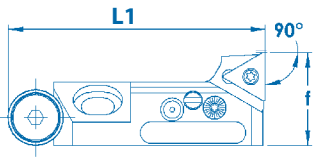
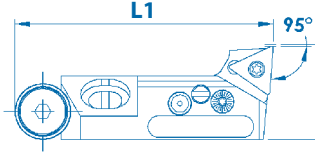
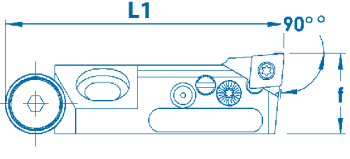
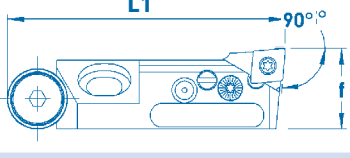
	Part Number	D (min bore Ø)		f		L1		Insert	Datum Rad	
		mm	inch	mm	inch	mm	inch		mm	inch
	UFP-1190 UFP-1190LH	36.0	1.417	20.0	0.787	55.5	2.185	TC or TP 11 02 ..	0.4	0.016
	UFP-1195 UFP-1195LH	36.0	1.417	20.0	0.787	55.5	2.185	TC or TP 11 02 ..	0.4	0.016
	UFP-1290	75.0	2.953	32.0	1.260	107.0	4.213	CC or CP 12 04 ..	0.8	0.031
	UFP-1690	75.0	2.953	32.0	1.260	107.0	4.213	TC or TP 16 03 ..	0.8	0.031

## UFP Cartridges Technical Specification

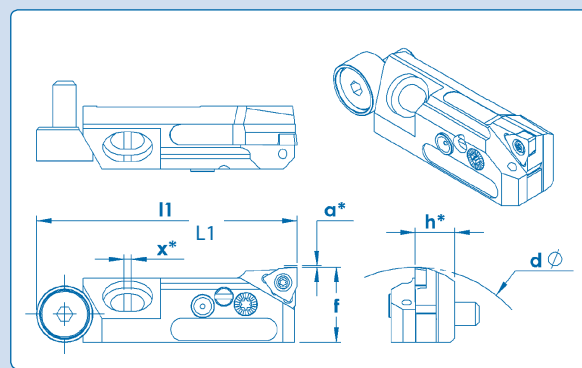

- **a\*** - 0.3 adjustment on all UFP's, adjustment = 0.005mm per division on diameter
- **h\*** - 8.5 on UFP 06-11, 18.0 on UFP 12-16
- **x\*** - 1.0 on UFP 06-11, 1.6 on UFP 12-16

For mounting dimensions please see the 'Smartbore & UFP Mounting Dimensions' section on page 6.

## UFP Cartridges Spares & Accessories

UFP	Clamp Screw	Hexagon Wrench for Clamp Screw	Axial Adjusting Screw	Axial Wedge	Insert Screw	Torx Wrench for Insert Screw	Grease Gun	Hexagon Wrench for Axial Screw	Torx Wrench for Adjustment Screw
Standard	WS360	R58	WS359	WP311	RS2560	R37	UFPG_00	R48	R57 (T10)
Large (1290, 1690)	WS1035	R108	WS830	WP411	RS40120	R87 R77		R88	

## ISO and Small Cartridges

Rigibore ISO (lay in) cartridges are available in a wide range of styles and sizes for all applications, including:

06CAx7, 06CA, 08CA, 10CA, 12CA (16CA available to order)

Standard stocked ISO and small cartridges

### Great choice

Complete range held in stock

### Outstanding value

Phone today or send an enquiry through our website for best prices and delivery times

### Minimum bore

15.6mm/0.614"

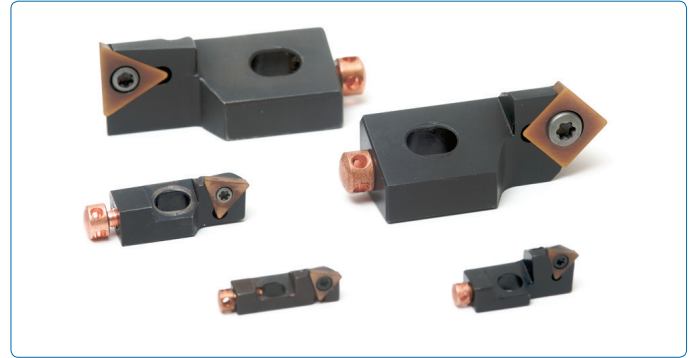
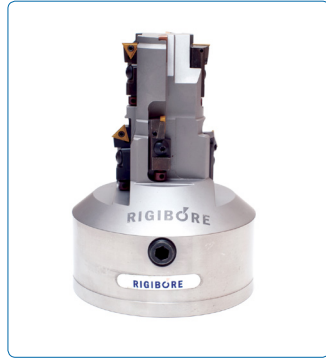

● Tools for building-in

● Full range available

## ISO and Small Cartridges Technical Specification

Right hand – Shown  
Left hand – Mirror image

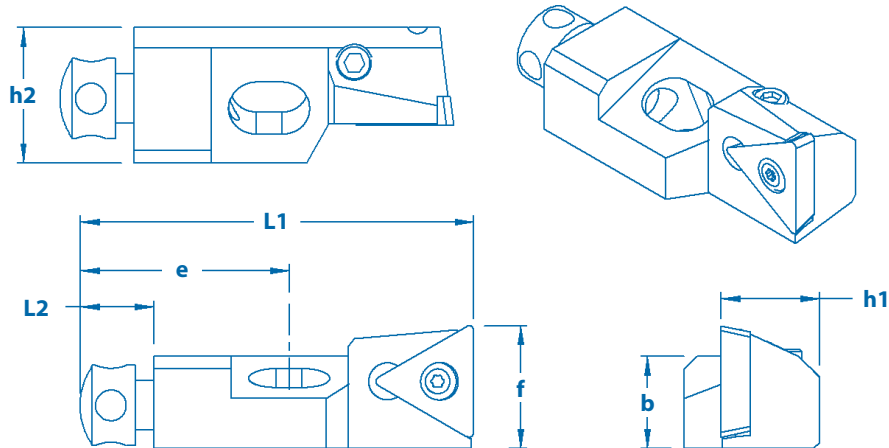

Style/Size	Axial Adjustment	
	mm	inch
06CAx7	± 0.5	± 0.0197
06CA	± 0.5	± 0.0197
08CA	± 1.0	± 0.0394
10CA	± 1.0	± 0.0394
12CA	± 1.0	± 0.0394
16CA	± 1.5	± 0.0591

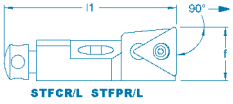
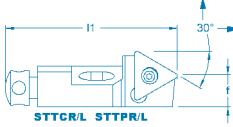
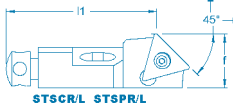
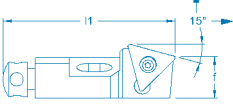
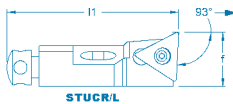
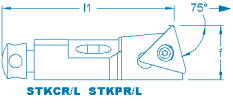

## ISO and Small Cartridges Technical Specification

	Part Number	L1		L2		b		h1		h2		f		e		Insert	Datum Rad	
		mm	inch	mm	inch	mm	inch	mm	inch	mm	inch	mm	inch	mm	inch		mm	inch
	STFCR/L 06CA-06X7	24.5	0.965	4.5	0.177	4.5	0.177	6.0	0.236	6.0	0.236	7.0	0.276	12.0	0.472	TC06..T1..	0.2	0.008
	STFCR/L 06CA-06	25.0	0.984	4.5	0.177	5.0	0.197	6.0	0.236	8.0	0.315	8.0	0.315	12.0	0.472	TC06..T1..	0.4	0.016
	STFPR/L 06CA-06															TP06..T1..		
	STFCR/L 08CA-09	32.0	1.260	6.0	0.236	7.5	0.295	8.0	0.315	11.0	0.433	10.0	0.394	17.0	0.669	TC..0902..	0.4	0.016
	STFPR/L 08CA-09															TP..0902..		
	STFCR/L 10CA-11	50.0	1.969	8.0	0.315	11.0	0.433	10.0	0.394	15.0	0.591	14.0	0.551	20.0	0.787	TC..1102..	0.4	0.016
	STFPR/L 10CA-11															TP..1102..		
	STFCR/L 12CA-16	55.0	2.165	8.0	0.315	15.0	0.591	12.0	0.472	20.0	0.787	20.0	0.787	20.0	0.787	TC..16T3..	0.8	0.031
	STFCR/L 12CA-16															TP..16T3..		
	STFCR/L 16CA-16	63.0	2.480	8.0	0.315	20.0	0.787	16.0	0.630	20.0	0.787	25.0	0.984	25.0	0.984	TC..16T3..	0.8	0.031
STFPR/L 16CA-16	TP..16T3..																	
	STTCR/L 06CA-06X7	24.5	0.965	4.5	0.177	4.5	0.177	6.0	0.236	6.0	0.236	3.7	0.146	12.0	0.472	TC..16T3..	0.2	0.008
	STTCR/L 06CA-06	25.0	0.984	4.5	0.177	5.0	0.197	6.0	0.236	8.0	0.315	5.5	0.217	12.0	0.472	TC..06T1..	0.4	0.016
	STTPR/L 06CA-06															TP..06T1..		
	STTCR/L 08CA-09	32.0	1.260	6.0	0.236	7.5	0.295	8.0	0.315	11.0	0.433	6.0	0.236	17.0	0.669	TC..0902..	0.4	0.016
	STTPR/L 08CA-09															TP..0902..		
	STTCR/L 10CA-11	50.0	1.969	8.0	0.315	11.0	0.433	10.0	0.394	15.0	0.591	9.0	0.354	20.0	0.787	TC..1102..	0.4	0.016
	STTPR/L 10CA-11															TP..1102..		
	STTCR/L 12CA-16	55.0	2.165	8.0	0.315	15.0	0.591	12.0	0.472	20.0	0.787	13.0	0.512	20.0	0.787	TC..16T3..	0.8	0.031
	STTPR/L 12CA-16															TP..16T3..		
		STSCR/L 06CA-06X7	24.5	0.965	4.5	0.177	4.5	0.177	6.0	0.236	6.0	0.236	7.0	0.276	12.0	0.472	TC..06T1..	0.2
STSCR/L 06CA-06		21.0	0.827	4.5	0.177	5.0	0.197	6.0	0.236	8.0	0.315	8.0	0.315	12.0	0.472	TC..06T1..	0.4	0.016
STSPR/L 06CA-06																TP..06T1..		
STSCR/L 08CA-09		28.0	1.102	6.0	0.236	7.5	0.295	8.0	0.315	11.0	0.433	10.0	0.394	17.0	0.669	TC..0902..	0.4	0.016
STSPR/L 08CA-09																TP..0902..		
STSCR/L 10CA-11		44.0	1.732	8.0	0.315	11.0	0.433	10.0	0.394	15.0	0.591	14.0	0.551	20.0	0.787	TC..1102..	0.4	0.016
STSPR/L 10CA-11																TP..1102..		
STSCR/L 12CA-16		47.0	1.850	8.0	0.315	15.0	0.591	12.0	0.472	20.0	0.787	20.0	0.787	25.0	0.984	TC..16T3..	0.8	0.031
STSPR/L 12CA-16																TP..16T3..		
		STRCR/L 08CA-09	32.0	1.260	6.0	0.236	7.5	0.295	8.0	0.315	11.0	0.433	7.8	0.307	17.0	0.669	TC..0902..	0.4
	STRPR/L 08CA-09	TP..0602..																
	STUCR/L 08CA-09	32.0	1.260	6.0	0.236	7.5	0.295	8.0	0.315	11.0	0.433	10.0	0.394	17.0	0.669	TC..0902..	0.4	0.016
	STKCR/L 06CA-06X7	24.5	0.965	4.5	0.177	4.5	0.177	6.0	0.236	6.0	0.236	7.0	0.276	12.0	0.472	TC..06T1..	0.2	0.008
	STKCR/L 06CA-06	25.0	0.984	4.5	0.177	5.0	0.197	6.0	0.236	8.0	0.315	8.0	0.315	12.0	0.472	TC..06T1..	0.4	0.016
	STKPR/L 06CA-06															TP..06T1..		
	STKCR/L 08CA-09	32.0	1.260	6.0	0.236	7.5	0.295	8.0	0.315	11.0	0.433	10.0	0.394	17.0	0.669	TC..0902..	0.4	0.016
	STKPR/L 08CA-09															TP..0902..		

Continued...

Continued...

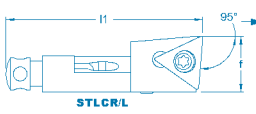
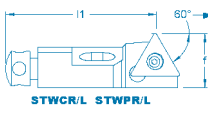
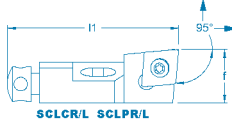
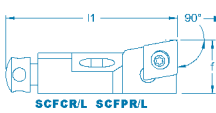
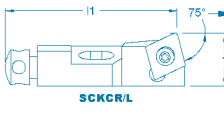
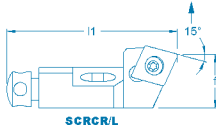
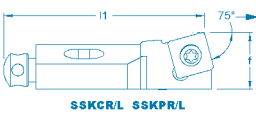
	Part Number	L1		L2		b		h1		h2		f		e		Insert	Datum Rad	
		mm	inch	mm	inch	mm	inch	mm	inch	mm	inch	mm	inch	mm	inch		mm	inch
 <p>STLCR/L</p>	STLCR/L 06CA-06X7	24.5	0.965	4.5	0.177	4.5	0.177	6.0	0.236	6.0	0.236	7.0	0.276	12.0	0.472	TC06..T1..	0.2	0.008
 <p>STWCR/L STWPR/L</p>	STWCR/L 06CA-06X7	21.0	0.827	4.5	0.177	4.5	0.177	6.0	0.236	6.0	0.236	7.0	0.276	12.0	0.472	TC06..T1..	0.2	0.008
	STWCR/L 06CA-06	21.0	0.827	4.5	0.177	5.0	0.197	6.0	0.236	8.0	0.315	8.0	0.315	12.0	0.472	TC06..T1..	0.4	0.016
	STWPR/L 06CA-06															TP06..T1..		
	STWCR/L 08CA-09	28.0	1.102	6.0	0.236	7.5	0.295	8.0	0.315	11.0	0.433	10.0	0.394	17.0	0.669	TC..0902..	0.4	0.016
STWPR/L 08CA-09	TP..0902..																	
 <p>SCLCR/L SCLPR/L</p>	SCLCR/L 08CA-06	32.0	1.260	6.0	0.236	7.5	0.295	8.0	0.315	11.0	0.433	10.0	0.394	17.0	0.669	CC..0602..	0.4	0.016
	SCLPR/L 08CA-06															CP..0602..		
 <p>SCFCR/L SCFPR/L</p>	SCFCR/L 08CA-06	32.0	1.260	6.0	0.236	7.5	0.295	8.0	0.315	11.0	0.433	10.0	0.394	17.0	0.669	CC..0602..	0.4	0.016
	SCFPR/L 08CA-06															CP..0602..		
	SCFCR/L 10CA-09	50.0	1.969	8.0	0.315	11.0	0.433	10.0	0.394	15.0	0.591	14.0	0.551	20.0	0.787	CC..09T3..	0.8	0.031
	SCFPR/L 10CA-09															CP..09T3..		
 <p>SCKCR/L</p>	SCKCR/L 08CA-06	32.0	1.260	6.0	0.236	7.5	0.295	8.0	0.315	11.0	0.433	10.0	0.394	17.0	0.669	CC..0602..	0.4	0.016
 <p>SCRCR/L</p>	SCRCR/L 08CA-06	32.0	1.260	6.0	0.236	7.5	0.295	8.0	0.315	11.0	0.433	10.0	0.394	17.0	0.669	CC..0602..	0.4	0.016
 <p>SSKCR/L SSKPR/L</p>	SSKCR/L 10CA-09	50.0	1.969	8.0	0.315	11.0	0.433	10.0	0.394	15.0	0.591	14.0	0.551	20.0	0.787	SC..09T3..	0.8	0.031
	SSKPR/L 10CA-09															SP..09T3..		
	SSKCR/L 12CA-12	55.0	2.165	8.0	0.315	15.0	0.591	12.0	0.472	20.0	0.787	20.0	0.787	20.0	0.787	SC..1204..	0.8	0.031
	SSKPR/L 12CA-12															SP..1204..		

## ISO and Small Cartridges Mounting Dimensions

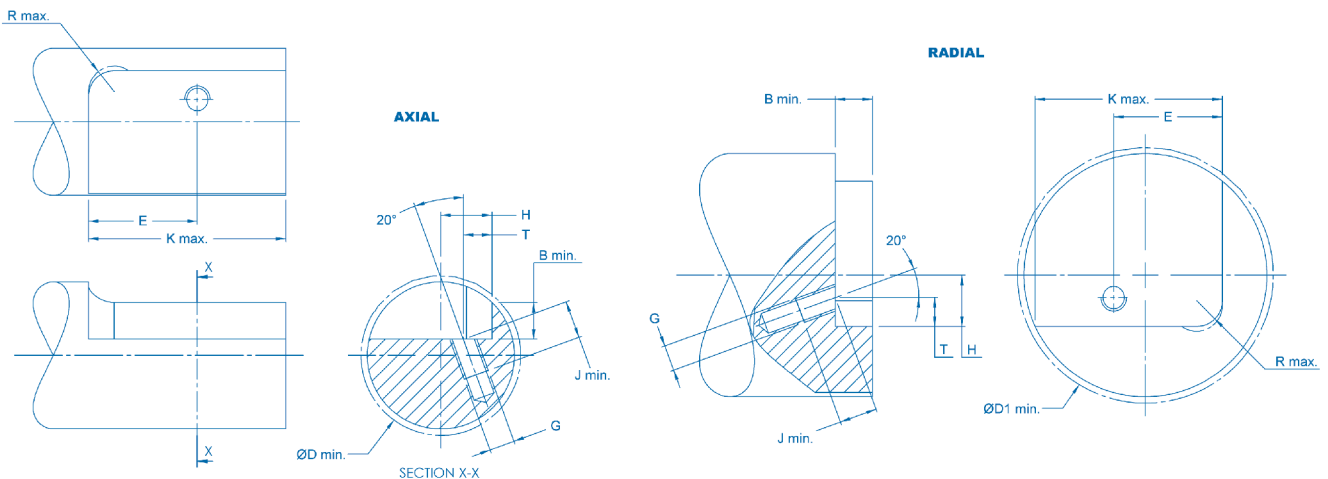

Cartridge	D Min		D1		E		K Max		G	J Min		H		T +0-0.15		B Min		R Min	
	mm	inch	mm	inch	mm	inch	mm	inch		mm	inch	mm	inch	mm	inch	mm	inch	mm	inch
06CA-06X7	15.6	0.614	30.0	1.181	12.0	0.472	23.5	0.925	M3 x 0.5	5.5	0.217	5.5	0.217	2.5	0.098	4.0	0.157	2.5	0.098
06CA-06	20.0 <sup>1</sup>	0.787	31.0	1.220	12.0	0.472	24.0	0.945	M3.5 x 0.5	6.0	0.236	6.0	0.236	3.5	0.138	5.0	0.197	2.5	0.098
08CA	25.0 <sup>2</sup>	0.984	38.0	1.496	17.0	0.669	30.5	1.201	M4 x 0.7	6.5	0.256	8.0	0.315	4.5	0.177	5.8	0.228	4.0	0.157
10CA	40.0	1.575	55.0	2.165	20.0	0.787	48.5	1.909	M6 x 1.0	14.0	0.551	10.0	0.394	5.0	0.197	9.0	0.354	4.0	0.157
12CA	50.0	1.969	75.0	2.953	20.0	0.787	48.5	1.909	M6 x 1.0	14.0	0.551	12.0	0.472	6.0	0.236	13.0	0.512	5.0	0.197
16CA	55.0	2.165	75.0	2.953	25.0	0.984	61.0	2.402	M8 x 1.25	16.0	0.630	15.0	0.591	0(@45°)	0.000	16.5	0.650	6.0	0.236

Note: the following are required for the 16CA-16 cartridge – SHIM RS4129 - SHIM SCREW RSS2471 - SHIM WRENCH R118

<sup>1</sup> D (Min) = 20.0 when H = 6.0 to ISO (but D (Min) = 19.0 is achievable with H = 5.5)

<sup>2</sup> D (Min) = 25.0 when H = 8.0 to ISO (but D (Min) = 20.0 is achievable with H = 7.0)

## ISO and Small Cartridges Mounting Dimensions

								
Cartridge	Insert Screw	Torx Wrench	Torx Driver	Mounting Screw	Hexagon Wrench (MTG)	Axial Adjustment Screw	Radial Adjustment Screw	Hexagon Wrench (Rada Adjustment)
06CA-06X7	RS2045	R27	R27D	C06X7/5	R28	C06X7/7	C06X7/8	C06X7/9
06CA-06	RS2045	R27	R27D	C06X8/14	R38	C06X7/7	C06X7/8	C06X7/9
08CA-09	RS2263	R37	R37D	C08X10/5	R38	C08X10/7	C08X10/8	C06X7/9
08CA-06	RS2560	R37	R37D	C08X10/5	R38	C08X10/7	C08X10/8	C06X7/9
10CA-09	RS4084	R77	R77D	C10X14/5	R58	C10X14/7	C10X14/8	R28
10CA-11	RS2560	R37	R37D	C10X14/5	R58	C10X14/7	C10X14/8	R28
12CA-12	RS40120	R87	R87D	C12X20/5	R58	C10X14/7	C12X20/8	R38
12CA-16	RS35100	R77	R77D	C12X20/5	R58	C10X14/7	C12X20/8	R38
16CA-16	RS35100	R77	R77D	C16X25/5	C16X25/6	C10X14/7	C16X20/8	R38

Continued...

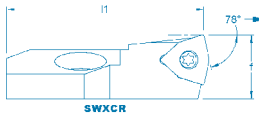
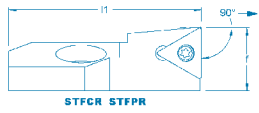
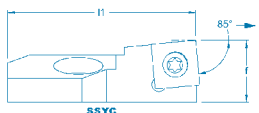
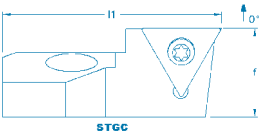
	Part Number	L1		b		h1		h2		f		e		Insert	Datum Rad	
		mm	inch	mm	inch	mm	inch	mm	inch	mm	inch	mm	inch		mm	inch
 <p>SWXCR</p>	SWXCR 08CX-03	25.0	0.984	6.5	0.256	8.0	0.315	11.0	0.433	9.0	0.354	10.0	0.394	WCGX0302..	0.4	0.016
	SWXCR 10CX-05	40.0	1.575	10.0	0.394	10.0	0.394	15.0	0.591	13.0	0.512	15.0	0.591	WCGX0503..	0.4	0.016
	SWXCR 10CX-05-HD													WCGX05T3..		
	SWXCR 12CX-06	44.0	1.732	13.0	0.512	12.0	0.472	20.0	0.787	18.0	0.709	14.0	0.551	WCGX0603..	0.4	0.016
	SWXCR 12CX-06-HD													WCGX06T3..		
	SWXCR 12CX-07	44.0	1.732	13.0	0.512	12.0	0.472	20.0	0.787	18.0	0.709	14.0	0.551	WCGX0703..	0.4	0.016
	SWXCR 12CX-07-HD													WCGX0704..		
	SWXCR 16CX-09	50.0	1.969	18.0	0.709	16.0	0.630	21.0	0.827	23.0	0.906	17.0	0.669	WCGX0904..	0.4	0.016
SWXCR 16CX-09-HD	WCGX0905..															
 <p>STFCR STFPR</p>	STFCR 10CX-11	40.0	1.575	10.0	0.394	10.0	0.394	15.0	0.591	13.0	0.512	15.0	0.591	TC..1102..	0.4	0.016
	STFPR 10CX-11													TP..1102..		
	STFCR 12CX-16	44.0	1.732	13.0	0.512	12.0	0.472	20.0	0.787	18.0	0.709	14.0	0.551	TC..16T3..	0.8	0.031
	STFPR 12CX-16													TP..16T3..		
 <p>SSYCR</p>	SSYCR 10CX-09	40.0	1.575	10.0	0.394	10.0	0.394	15.0	0.591	13.0	0.512	15.0	0.591	SC..09T3..	0.4	0.016
	SSYCR 12CX-12	44.0	1.732	13.0	0.512	12.0	0.472	20.0	0.787	18.0	0.709	14.0	0.551	SC..1204..	0.8	0.031
 <p>STGCR</p>	STGCR 12CX-16	44.0	1.732	13.0	0.512	12.0	0.472	20.0	0.787	18.0	0.709	14.0	0.551	TC..16T3..	0.8	0.031

## Negative CX Style Roughing Cartridges Technical Data

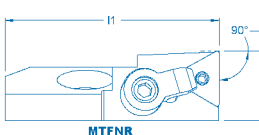
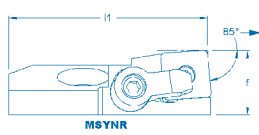
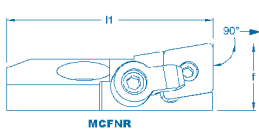
	Part Number	L1		b		h1		h2		f		e		Insert	Datum Rad	
		mm	inch	mm	inch	mm	inch	mm	inch	mm	inch	mm	inch		mm	inch
 <p>MTFNR</p>	MTFNR 10CX-11	40.0	1.575	10.0	0.394	10.0	0.394	18.8	0.740	13.0	0.512	15.0	0.591	TN..1103..	0.4	0.016
	MTFNR 12CX-16	44.0	1.732	13.0	0.512	12.0	0.472	23.5	0.925	18.0	0.709	14.0	0.551	TN..1604..	0.8	0.031
 <p>MSYNR</p>	MSYNR 10CX-09	40.0	1.575	10.0	0.394	10.0	0.394	20.4	0.803	13.0	0.512	15.0	0.591	SN..0903..	0.8	0.031
	MSYNR 12CX-12	44.0	1.732	13.0	0.512	12.0	0.472	23.6	0.929	18.0	0.709	14.0	0.551	SN..1204..	0.8	0.031
 <p>MCFNR</p>	MCFNR 10CX-09	40.0	1.575	10.0	0.394	10.0	0.394	18.9	0.744	13.0	0.512	15.0	0.591	CN..09T3..	0.8	0.031
	MCFNR 12CX-12	44.0	1.732	13.0	0.512	12.0	0.472	23.6	0.929	18.0	0.709	14.0	0.551	CN..1204..	0.8	0.031

## Inserts by Rigibore®

All areas of production catered for, including low speed roughing, interrupted cuts and optimised machining of specialised materials

Ground to ISO H tolerance, long lasting, fast metal removal

## Finishing

### Choice of geometries - Uncoated and coated grades

Inserts for cast iron, aluminum, steel, brass, bronze and titanium alloys

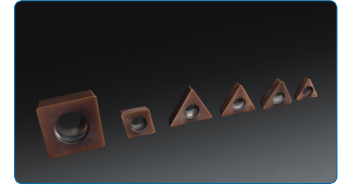
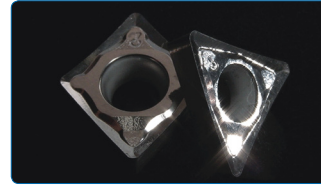

### Rigibore Insert Grades

Grade	I.S.O	ANSI	Description	Coating	Materials
RC217	M10 - M25 K05 - K25	C2-C3	High-speed finishing. Exceptional resistance to wear, oxidation & thermal shock	PVD composite coated	Cast iron heat-resisting titanium alloy
R71	P05-P25 M10-M20	P6-P7	Light roughing & finishing. High cutting speeds with moderate feeds. High resistance to wear & thermal shock	Uncoated	Steel, cast steel
R22	K10-K25 M10-M30	C2-C3	Wide range of applications. High resistance to wear & good edge sharpness. Moderate cutting	Micro-grain uncoated	Cast Iron, ferrous materials, heat resisting titanium alloy & aircraft aluminum

### Chipbreaker Geometries

A choice of 4 geometries is available to suit most applications Ultra-precision ground to I.S.O. "H" tolerance for indexing within .0005"/0.013mm	
0° T.R.	Brass, S.G. Cast Iron, hardened steel, short-chipping Bronze
8° T.R.	Alloy steels, tool steels, some bronzes, some grey cast irons & tougher materials
14° T.R.	Mild steels, stainless steels, some tool steels, heat-resisting steel alloys, hard plastics
22° T.R.	Aluminum, aluminum alloys, soft plastics, rubber, magnesium alloys, copper

### Inserts for Aluminum

Size	Order Code	Available Grades	d (I.C)		l*		d1		s		r	
			mm	inch	mm	inch	mm	inch	mm	inch	mm	inch
06-16	TCHT 06 11 04 FN-AL	R22	3.97	.156	6.87	.27	2.2	.087	1.98	.078	0.4	.016
	TCHT 09 02 04 FN-AL		5.56	.22	9.63	.38	2.5	.098	2.38	.094		
	TCHT 11 02 04 FN-AL		6.35	.25	11.0	.43	2.8	.11	2.38	.094		
	TCHT 16 T3 08 FN-AL		9.525	.375	16.5	.65	4.4	.17	3.97	.156	0.8	.031
06-12	CCHT 06 02 04 FN-AL	R22	6.35	.25	6.35	.25	2.8	.11	2.38	.094	0.4	.016
	CCHT 09 T3 08 FN-AL		9.525	.375	9.525	.375	4.4	.17	3.97	.156	0.8	.031
	CCHT 12 02 08 FN-AL		12.7	.5	12.7	.5	5.5	.217	4.74	.187		

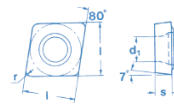
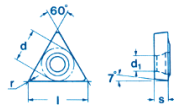

### Inserts for all uses

L = Left hand (boring), R = Right hand (turning)

Size	Order Code	Available Grades	Top Rake (deg)	d (I.C)		l*		d1		s		r				
				mm	inch	mm	inch	mm	inch	mm	inch	mm	inch			
06	TCHW 06 T1 02	RC217, R22	0	3.97	0.156	6.87	0.27	2.2	0.087	1.98	0.078	0.2	0.008			
	TCHW 06 T1 04											0.4	0.016			
	TCHW 06 T1 08	RC217										0.8	0.031			
	TCHX 06 T1 01 - L22	R22										22	0.1	0.004		
	TCHX 06 T1 02 - L08	R71										8	0.2	0.008		
	TCHX 06 T1 02 - L14											14				
	TCHX 06 T1 02 - L22	R22										22	0.4	0.016		
	TCHX 06 T1 04 - L08	R71										8				
09	TCHW 09 02 02	RC217, R22	0	5.56	0.219	9.63	0.379	2.5	0.098	2.38	0.094	0.2	0.008			
	TCHW 09 02 04											0.4	0.016			
	TCHW 09 02 08											0.8	0.031			
	TCHX 09 02 01 - L22	R22										22	0.2	0.008		
	TCHX 09 02 02 - L14	R71										14	0.2	0.008		
	TCHX 09 02 02 - L22	R22										22				
	TCHX 09 02 04 - L08	R71										8			0.4	0.016
	TCHX 09 02 04 - L14											14				
11	TCHW 11 02 02	RC217, R22	0	6.35	0.25	11	0.433	2.8	0.11	2.38	0.094	0.2	0.008			
	TCHW 11 02 04											0.4	0.016			
	TCHW 11 02 08											0.8	0.031			
	TCHX 11 02 01 - L22	R22										22	0.1	0.004		
	TCHX 11 02 02 - L08	R71										8	0.2	0.008		
	TCHX 11 02 04 - L08											14			0.4	0.016
	TCHX 11 02 04 - L14															
16	TCHW 16 T3 02	R22	0	9.525	0.375	16.5	0.65	4.4	0.173	3.97	0.156	0.2	0.008			
	TCHW 16 T3 04	RC217, R22										0.4	0.016			
	TCHW 16 T3 08											0.8	0.031			
	TCHW 16 T3 12											1.2	0.047			
	TCHX 16 T3 04 - L14	R71										14	0.4	0.016		
	TCHX 16 T3 08 - L22	R22										22	0.8	0.031		
06	CCHW 06 02 04	RC217, R22	0	6.35	0.25	6.35	0.25	2.8	0.11	2.38	0.094	0.4	0.016			
	CCHW 06 02 08											RC217	0.8	0.031		
	CCHX 06 02 04 - L14	14											0.2	0.008		
	CCHX 06 02 02 - L22	R22													22	
	CCHX 06 02 04 - L08	RC217, R22, R71										8	0.4	0.016		
	CCHX 06 02 04 - R08											R22			8	
	CCHX 06 02 04 - L14	R71										14				
09	CCHW 09 T3 04	RC217, R22	0	9.525	0.375	9.525	0.375	4.4	0.173	3.97	0.156	0.4	0.016			
	CCHW 09 T3 08											RC217	0.8	0.031		
	CCHX 09 T3 02 - L08	8											0.2	0.008		
	CCHX 09 T3 04 - L08	RC217, R71											8	0.4	0.016	
	CCHX 09 T3 08 - L08	RC217										0.8				0.031
12	CCHW 12 04 08	RC217	0	12.7	0.5	12.7	0.5	5.5	0.216	4.74	0.187	0.8	0.031			
04	CPHW 04 T1 04	RC217, R22	0	4.76	0.187	4.8	0.189	2.15	0.085	1.98	0.078	0.4	0.016			