

Mounting Dimensions Angular Mounted Units - R & TR Units

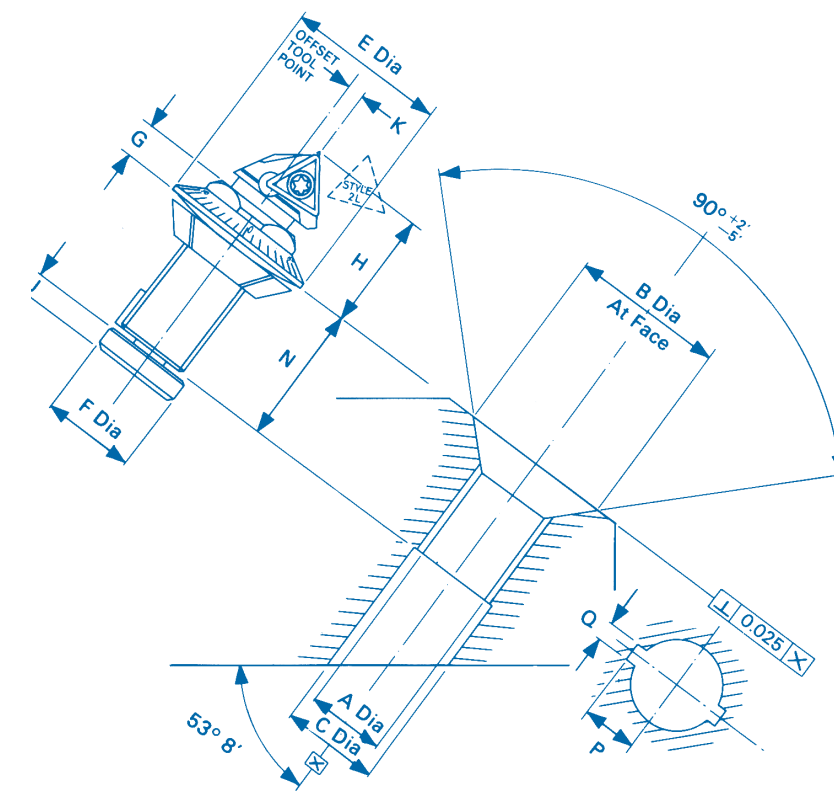

N.B
 'H' – over datum rad
 'K' – to sharp point
 For 'H' & 'K' please see
 Rigibore Unit Section

Technical Data – Hole Dimensions for Standard Rigibore Units – Metric

UNIT PREFIX	A +0.13 -0 Ø	B +0.13 -0 Ø	C +0.25 -0 Ø	D +/-0.25	E +/-0.05	F +/-0.1	G +0 -0.02	J +0.1 -0	M (Std)	N +0.25 -0	P +0.05 -0	Q +0.02 -0
R2B5										6.35		
R2B/TR2B_										9.50		
R2A/TR2A_	6.35	12.80	8.00	19.00	13.70	7.80	3.00	1.85	4.00		3.80	1.60
R2F/TR2F_										12.70		
R3B/TR3B_										11.90		
R3A/TR3A_	7.937	16.00	11.30	26.00	18.00	11.00	4.00	4.00	5.50		5.05	2.34
R3F/TR3F_										15.90		
R5B/TR5B_										19.00		
R5A/TR5A_	12.70	25.66	16.00	38.00	27.00	15.60	5.60	7.00	5.50		7.55	3.155
R5F/TR5F_										25.40		
R7B/TR7B_										25.40		
R7A/TR7A_	19.05	35.20	24.00	48.00	37.50	23.70	8.70	13.00	11.00		11.35	4.76
R7F/TR7F_										31.75		
R10B/TR10B_										35.00		
R10A/TR10A_	25.40	44.70	32.00	57.00	48.00	31.50	9.40	16.50	14.50		14.95	6.32
R10F/TR10F_										47.60		

Mounting Dimensions Square Mounted Units

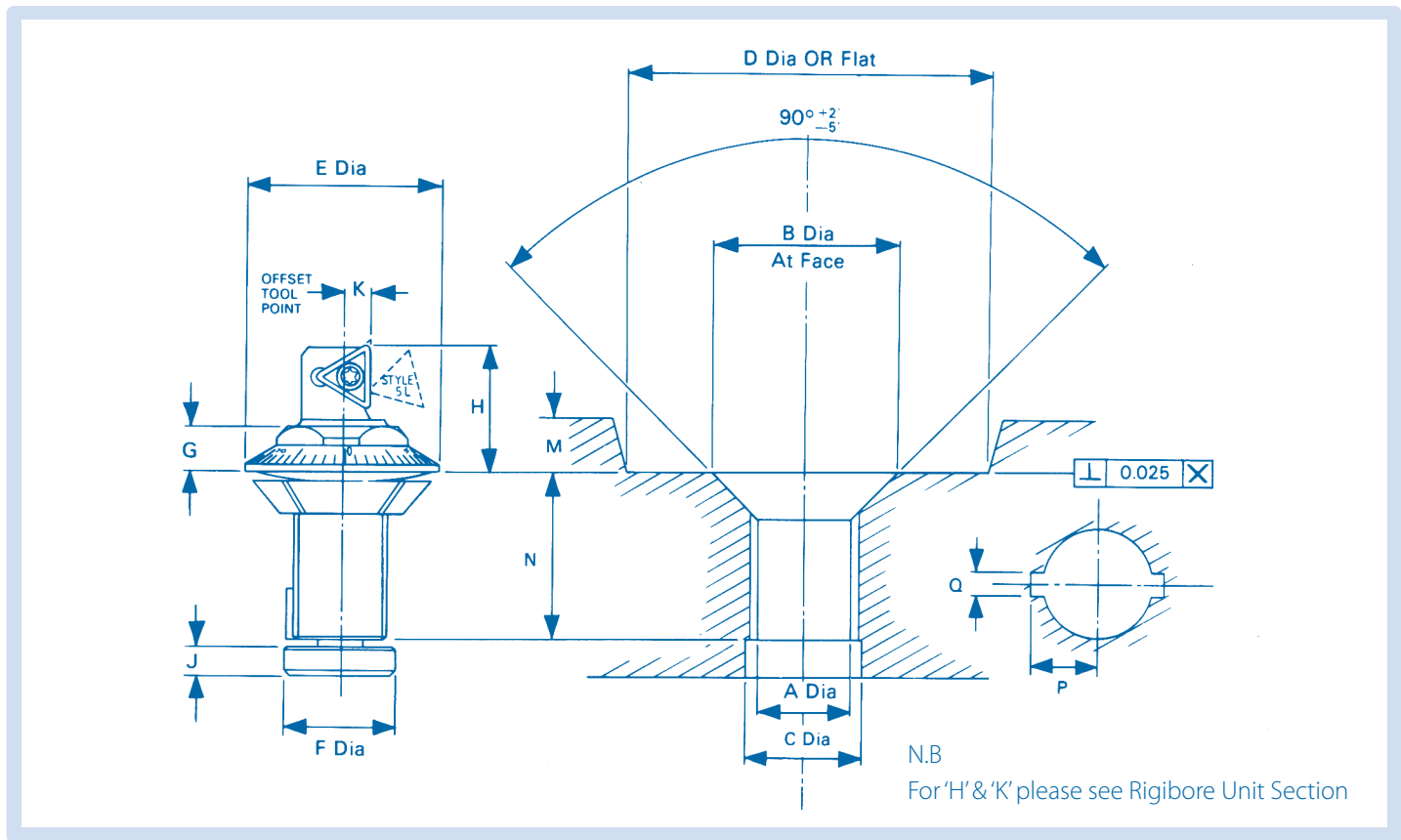

Technical Data – Mounting Dimensions for Standard Rigibore Units – Imperial

UNIT PREFIX	A +0.005 -0 Ø	B +0.005 -0 Ø	C +0.010 -0 Ø	D +0.01	E +/-0.002 Ø	F +/-0.004 Ø	G +0 -0.008	J +0.004 -0	M (Std)	N +0.010 -0 B/A	P +0.002 -0	Q +0.001 -0
R2B_S										.2500		
R2B_/TR2B_	.2500	.5040	.3150	.7500	.5400	.3070	.1180	.1180	.1570	.3750	.1500	.0630
R2A_/TR2A_										.5000		
R2F_/TR2F_												
R3B_/TR3B_	.3125	.6300	.4450	1.030	.7090	.4330	.1580	.1580	.2170	.4690	.1990	.0920
R3A_/TR3A_										.6250		
R3F_/TR3F_												
R5B_/TR5B_	.5000	1.010	.6300	1.500	1.063	.6100	.2200	.2760	.2170	.7500	.2970	.1240
R5A_/TR5A_										1.000		
R5F_/TR5F_												
R7B_/TR7B_	.7500	1.386	.9450	1.870	1.476	.9330	.3430	.5120	.4330	1.000	.4470	.1870
R7A_/TR7A_										1.250		
R7F_/TR7F_												
R10B_/TR10B_	1.000	1.760	1.260	2.250	1.890	1.240	.3700	.6500	.5710	1.375	.5890	.2490
R10A_/TR10A_										1.875		
R10F_/TR10F_												