



Smartbore

+0.002

**Smartbore**  
Micron accurate cutting edge tool adjuster

Finish boring tools with digital adjustment & display  
Accurate to one micron on diameter

**Contents**

**Page 3: What is Smartbore ?**

**Page 5: Smartbore Cartridges**

**Page 7: Smartbore Plus +**

**Page 10: Smartbore Nexus**

**Page 12: Smartbore FAQs**

**Page 13: Smartbore Case Studies**



## What is Smartbore ?

Smartbore is an innovative and unique solution for finish boring, providing a user-friendly way to make consistently accurate adjustments.

Smartbore works by electronically measuring real time movement of the cutting edge to an accuracy of one micron on diameter.

Available in a range of indexable cartridges, boring heads, a standard module for large diameter bores and a slide assembly, Smartbore is the most flexible 'digital' solution for finish boring applications in the market place.

Adjustment is made using the 'Smartbore Adjuster' - a digital torx wrench that both enables the adjustment and displays the adjustment value.

**Smartbore Boring Range :15mm - 1020mm \***

**Adjustment Range on diameter : 0.6mm**

**Accuracy :1µm on diameter**

**Smartbore products do not need to be clamped.**

**NO CLAMPING = NO DEFLECTION**



\*Range dependent on the product type

## The Smartbore Adjuster

Sensors in the adjuster monitor the exact position of the insert slide and swivel barrel orientation enables viewing in horizontal or vertical spindle position.



Exact adjustments are displayed clearly on the LCD screen

Adjustments are made by rotating the adjuster handle

## Features & Benefits



Machine operators of all skill & experience levels can accurately set the cutting edge.

Adjustments are made without removing the tool from the machine, minimising downtime

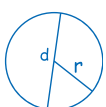
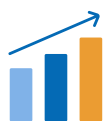

Measurement can be toggled between radius & diameter, metric & imperial, boring & over-turning

No clamping or un-clamping required after adjustment - ensuring accuracy every time



## Smartbore Product Range

The Smartbore product range consists of a wide range of finishing cartridges, a fine-adjusting slide assembly, a standard module for large diameter boring (Nexus) and a range of standard boring heads (Plus+).

The Smartbore adjuster can be used with all types of tooling in the Smartbore range.



Cartridges  
Range: from 28mm



Smartbore Plus+  
Range: 15-51mm



Smartbore Nexus  
Range: 275-1020mm



Fine-adjusting slide  
Range: from 16mm

## Smartbore Cartridges

Smartbore finishing cartridges are used for precision machining on single or multi-feature special tools.

Smartbore cartridges are designed with pockets to hold ISO inserts from sizes 06 - 16.



## Reduce Cycle Time

Smartbore cartridges are built into special tools which are designed and manufactured to suit your specific application.

Any number of cartridges can be built into a boring tool to machine multiple features.

✓ Micron accurate cartridge adjustment to one micron on diameter. 0.6mm adjustment range.

✓ Multi-cartridge tooling capabilities reduce cycle time







✓ Available as replaceable cartridges or built-in slide assembly

✓ Precise adjustment values displayed clearly on the adjuster, not the tool

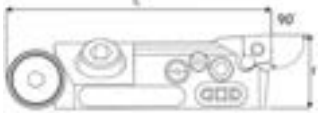
✓ 'One Shot' tooling improves process efficiency, reduced cycle time and minimises tooling requirements.

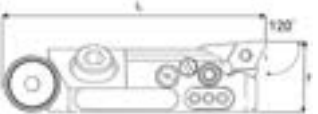

## Smartbore Cartridge Technical Specification

	Part Number	Min bore dia (mm)	f (mm)	L <sub>1</sub> (mm)	Insert	Datum Rad (mm)
 <p>SB-UFP0690 SB-UFP0690LH SB-UFP0690 (RH &amp; LH)</p>		28.0	16.0	55.5	CC..0602..	0.4
 <p>SB-UFP1190 SB-UFP1190LH SB-UFP1190 (RH &amp; LH)</p>		36.0	20.0	55.5	TC..1102..	0.4
 <p>SB-UFP0695 SB-UFP0695LH SB-UFP0695 (RH &amp; LH)</p>		28.0	16.0	55.5	CC..0602..	0.4
 <p>SB-UFP1195 SB-UFP1195LH SB-UFP1195 (RH &amp; LH)</p>		36.0	20.0	55.5	TC..1102..	0.4
 <p>SB-UFP07120 SB-UFP07120LH SB-UFP07120 (RH &amp; LH)</p>		28.0	16.0	55.5	DC..0702..	0.4
 <p>SB-UFP1290 SB-UFP1290 (RH)</p>		75.0	32.0	107.0	CC..1204..	0.4
 <p>SB-UFP1690 SB-UFP1690 (RH)</p>		75.0	32.0	107.0	TC..16T3..	0.4

## Smartbore Cartridge Technical Specifications

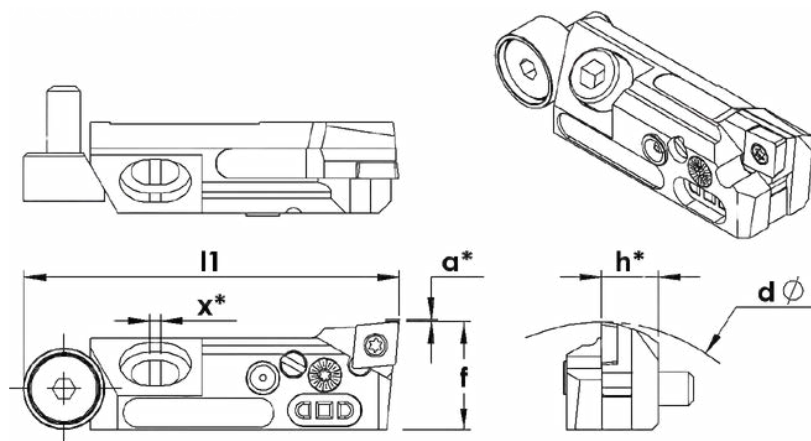

a\* : 0.3mm adjustment range

0.001mm per division on diameter

h\* : 8.5 (UFP06-11)  
18.0 (UFP12-16)

x\* : 1.0 (UFP06-11)  
1.6 (UFP12-16)

Right hand shown  
Left hand mirror image

## Mounting Dimensions

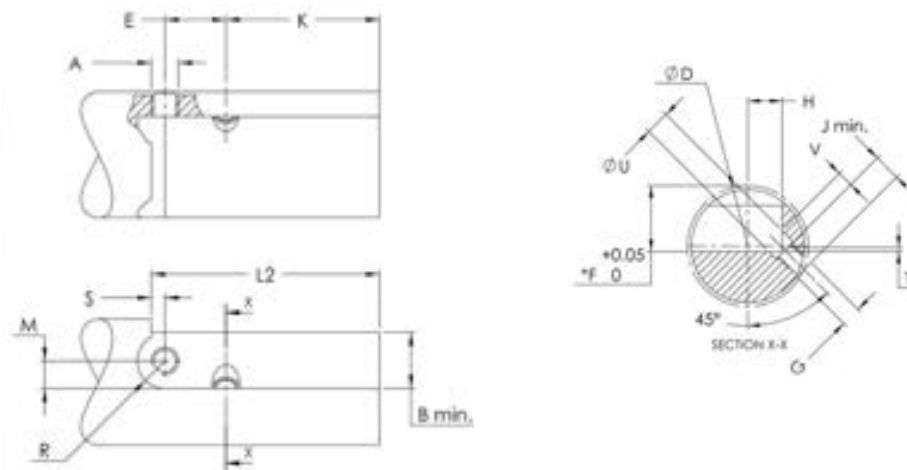

UFP	A	B (min)	H	L2	R	S	K	G	T	U(diam)	V	J (min)	E	M
		mm	mm	mm	mm	mm	mm		mm	mm	mm	mm	mm	mm
UFP06-11	M5X0.8	12.5	8.5	47.5	6.1	3.0	34.0	M5X.08	1.0	6.0	4.0	5.0	13.5	6.1
UFP12 & 16	M10X1.5	24.6	18.0	98.0	10.1	3.0	63.0	M10X1.5	1.4	11.0	8.0	10.0	32.0	10.0

## Spares & Accessories

UFP	Clamp Screw	Hexagon Wrench for Clamp Screw	Axial Adjusting Screw	Axial Wedge	Insert Screw	Torx Wrench for Insert Screw	Grease Gun	Hexagon Wrench for Axial Screw	Torx Wrench for Adjustment Screw	Smartbore Adjuster	Battery Charger
Standard 06-11	WS360	R58	WS359	WP311	RS2560	R37	UFGP-00	R48	-	SB-ADJ187	SB-CHR07
SB-UFP1290 SB-UFP1690	WS1035	R108	WS830	WP411	RS40120 RS4084	R87 R77	UFGP-00	R88	R57	SB-ADJ187	SB-CHR07

## Smartbore Plus+

The Smartbore Plus boring head is suitable for a range of bore sizes. Adjustment is quick and simple using coarse adjustment and fine adjustment using the Smartbore Adjuster.

### Smartbore Plus+ Overview

Smartbore Plus boring heads cover a range from 15mm diameter.

SB-M15	15mm/0.590 inches - 18.5mm/0.728 inches	(CC insert)
SB-M18	18mm/0.709 inches - 22mm/0.866 inches	(TP/CC insert)
SB-M20	20mm/0.787 inches - 31mm/1.220 inches	(TP/CC insert)
SB-M30	30mm/1.338 inches - 41mm/1.614 inches	(CC insert)
SB-M40	40mm/1.574 inches - 51mm/2.007 inches	(CC insert)

### Micron Accurate Adjustment

The coarse adjustment capability allows the tool to be set quickly and accurately across a range of bore sizes. There is 3.5mm of coarse adjustment on diameter.

Micron accurate fine adjustments are made using the Smartbore Adjuster (Digital Torx Wrench). Coarse and fine adjustment measures combine to offer flexibility and accuracy in setting bore sizes.



A range of bore sizes can be quickly covered using the coarse adjustment feature



For optimal performance the Smartbore Plus head should be mounted in a precision collet chuck



Rigid design avoids the risk of movement from clamping / unclamping



The Smartbore Plus boring head range supports CC04, CC06 & TP08 inserts

## Smartbore Plus Technical Specifications

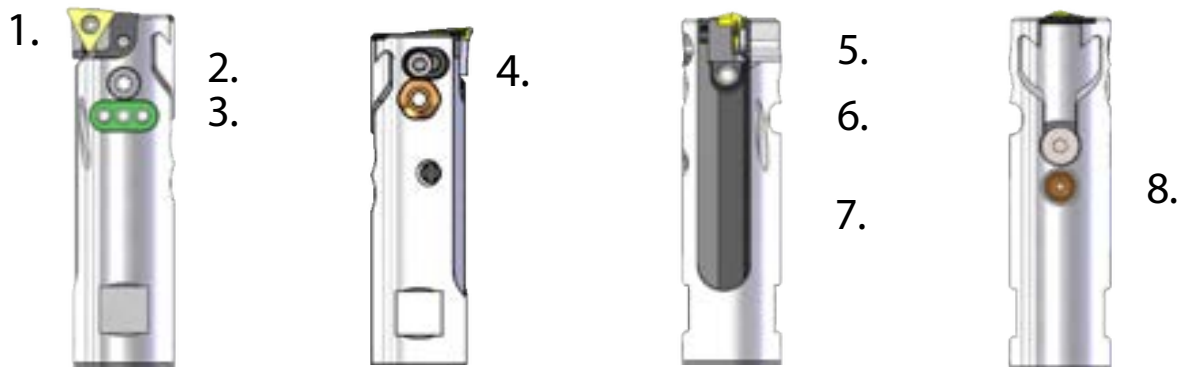

### Smartbore Plus+ Components

1. Insert	2. Fine Adjustment Torx Screw	3. Electronic Interface	4. Coarse Adjustment Locking Screw
5. Insert Holder	6. Coarse Adjustment Screw	7. Insert Slide	8. Lubrication Point

Total adjustment range: 0.30mm on radius

Smartbore Plus Head	Part Number	Insert	Diameter Range	Shank Length	Shank Diameter	Tool Body Length	Coarse Adjust	Approach Angle
			mm	mm	mm	mm	mm	°
	SB-M15	CC04	15-18.5	95	14	50	1.75	93°
	SB-M18 *	CC06 TP08	18-22	77.5	16	57	2.0	93°
	SB-M20 *	CC06 TP08	20-31 **	75	18	46	5.5	93°
	SB-M30	CC06	30-41**	100	25	50	3	93°
	SB-M40	CC06	40-51**	130	25	50	3	93°

\* SB-M18 & SB-M20 are supplied with insert shoes to suit both CC06 and TP08 inserts.

\*\* Diameter is achieved across two separate insert shoes.

\*\*All Smartbore Plus heads are supplied with the shank..

**Smartbore Plus+ Spares & Accessories**

Part Number	 Hexagon Wrench for Clamp Screw	 Insert Screw	 Torx Wrench for Insert Screw	 Smartbore Adjuster	 Battery Recharger	 Grease Gun
SB-M15	R28	TS21	R27	SB-ADJ187	SB-CHR07	UFGP-00
SB-M18-CC06 SB-M18-TP08	R28	RS2560	R37	SB-ADJ187	SB-CHR07	UFGP-00
SB-M20-CC06 SB-M20-TP08	R28	RS2543	R37	SB-ADJ187	SB-CHR07	UFGP-00
SB-M30	R38	RS2543	R37	SB-ADJ187	SB-CHR07	UFGP-00
SB-M40	R38	RS2543	R37	SB-ADJ187	SB-CHR07	UFGP-00

**CARTRIDGE MAINTENANCE**

Smartbore cartridges require regular maintenance to ensure optimal performance and durability, especially when machining cast iron



Grease Nipple

**Greasing Process**

The greasing process is designed to flush out small chips and machining dust that may build up in the cartridge mechanism. Grease should be pumped into the cartridge via the grease nipple until it emerges clean from around the slide as shown.

The correct operation and micron accuracy of the adjustment will be negatively affected unless the schedule below is adhered to.

**Essential Maintenance**

Material / Usage	Heavy Usage	Medium Usage	Light Usage
Ferrous (Cast Iron) - no coolant	3 / week	2 / week	1 / week
Ferrous (Cast Iron)	2 / week	1 / week	1 / week
Ferrous (Steel)	1 / week	1 - 2 weeks	1 / month
Non-ferrous	1 - 2 weeks	1 / month	6 / year

**Grease & Grease Applicator**



Our grease applicator is supplied with a refill with approx 120g of grease.

Grease applicator / gun can be purchased from Rigibore

Part Number: UFGP-00  
Grease Gun & Refill

Part Number: UFGP-00RFL  
Grease Refill

Rigibore recommends  
Castrol Tribol GR 100-1 PD



## Smartbore Nexus - Module for large diameter boring

Smartbore Nexus is designed for large diameter finish boring operations.

The Smartbore Nexus Module is used with standard boring flanges and holds a Smartbore cartridge (SB-UFP1290).

The boring diameter ranges from 275mm - 1020mm. (10.8268" - 40.15748")



The Nexus is a self-contained module that is assembled to a standard flange.

The Smartbore cartridge is mounted on the block and adjusted using the Smartbore Adjuster.



The Nexus balance block is adjusted radially to bring the tool into balance after Nexus is preset to the required diameter



### For boring

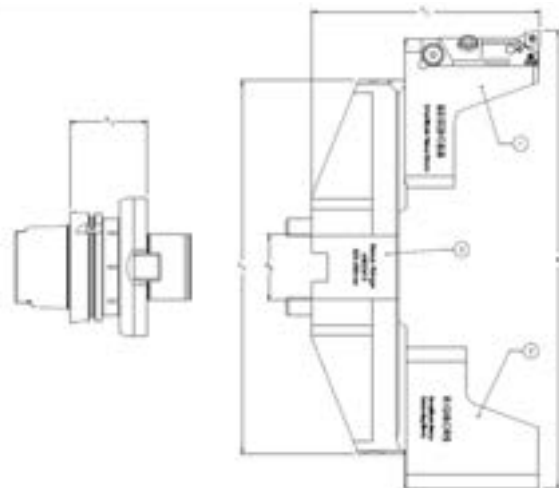

1. Smartbore Nexus Block - SB-NXF01
2. Smartbore Balance Block - SB-NX-BB
3. Nexus Flange - NXF-FL01

\* Flange Adaptor shown is HSK100A but other adaptors on other shanks are available. E.g. BT50, MVS100, 7388-50. Flange adaptor price is dependent on length.

Nexus Module	Balance Block	Cutting Range (mm)	Flange	Flange Adaptor	X1 (mm)	D5 (mm)
SB-NXF01	SB-NX-BB	275-355	NXF-FL01	-	208	D60
		350-430	NXF-FL02	-	208	D60
		425-505	NXF-FL03	-	208	D60
		465-745	NXF-FL04	NX-FA	262	D60
		740-1020	NXF-FL05	NX-FA	262	D60

**For overturning**

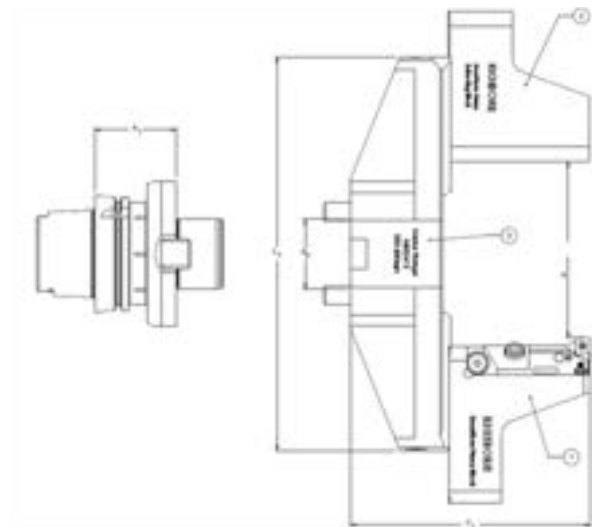

1. Smartbore Nexus Block - SB-NXF01
2. Smartbore Balance Block - SB-NX-BB
3. Nexus Flange - NXF-FL01

\* Flange Adaptor shown is HSK100A but other adaptors on other shanks are available. E.g. BT50, MVS100, 7388-50. Flange adaptor price is dependent on length.

Nexus Module	Balance Block	Cutting Range (mm)	Flange	Flange Adaptor	X1 (mm)	D5 (mm)
SB-NXF01	SB-NX-BB	Note 1	NXF-FL01	-	208	D60
		Note 1	NXF-FL02	-	208	D60
		Note 1	NXF-FL03	-	208	D60
		465-745	NXF-FL04	NX-FA	262	D60
		740-1020	NXF-FL05	NX-FA	262	D60

Note 1: Please contact Rigibore for more information. \* Cutting length can be increased with custom spacers.



**For large diameter boring**

## Smartbore FAQs

### How durable is the Smartbore hand-held adjuster?

The Smartbore adjuster has been rigorously tested to ensure that there is minimal risk of damage even in the harshest machining environments. Adjustments can be made in the machine spindle without risking damage from dust, oil, chips or coolant that may collide with the tool. The adjuster is so durable that it will maintain full functionality even if it is dropped into coolant or water.

### What adjustment ranges do Smartbore tools cover?

Rigibore's patented Smartbore technology covers a wide adjustment range for boring applications. Smartbore cartridges have an adjustment range from 16mm and are built into the bar as a slide assembly or as a cartridge based solution. Alternatively, for small hole boring operations, the Smartbore Nano boasts an adjustment range from 16mm down to 0.5mm in diameter.

### How prone to damage is the handheld Smartbore adjuster?

The Smartbore adjuster's sophisticated design minimises the risk of damage during use. By applying a constant preload and determining adjustments using sensor technology the adjuster doesn't apply more torque than required thereby eliminating the risk of damage. If accidentally dropped during the adjustment process, the torx head will spring back inside the adjuster. If damage to the torx driver occurs in operation, the adjuster can be returned to Rigibore for repair.

### How does communication between the Smartbore cartridge and adjuster work?

The Smartbore cartridge contains an integral position transducer. This is activated by the adjuster when the connection is made. The adjuster has a rechargeable power source and the control electronics necessary to display the adjustment reading on the LCD display screen. The adjuster also supplies power to the cartridge position transducer when connected. The transducer returns position data to the adjuster which is then interpreted and displayed on the LCD display screen.

### What capabilities does the Smartbore adjuster have for monitoring diameter changes?

The Smartbore adjuster displays can be changed depending on the boring operation and the operator's preference. The measurement system can be toggled between 'mm' and 'inch' by using the menu button. The adjustment type can also be toggled between 'RADIUS' and 'DIAMETER' to suit the operator's needs. The adjuster also offers adjustment based on the type of diameter change, displaying both 'BORING' and 'OVERTURNING' capabilities.

### Are Smartbore cartridges interchangeable with UFP Cartridges?

Smartbore cartridges are designed to fit UFP cartridge pockets, and are completely interchangeable with standard UFP cartridges.

### How can the Smartbore adjuster be charged in case of a flat battery ?

There is a recharger (SB-CHR07) for the Smartbore adjuster. The re-charger can be purchased with the adjuster or separately if required. The Smartbore Adjuster can be fully charged from flat battery in under an hour.

### Is the Smartbore adjustment system relative or absolute in it's adjustment methods?

Smartbore adjustments are based on an absolute scale, beginning at 0 and monitoring positive or negative diameter changes in a certain direction from the established starting point.

The adjuster's capabilities do not account for a relative measurement scale, meaning it can not establish the current diameter of the tool's cutting edge and therefore must be predetermined before making an adjustment.

### Do you have to calibrate the Smartbore adjuster?

No, the Smartbore adjuster is fully calibrated before dispatch from Rigibore and is ready for use upon arrival.

## Case Studies

### Connecting Rods Case Study

#### Project Overview

Smartbore was selected to improve the efficiency of connecting rod machining. Prior to the implementation the customer was using a boring bar with a bladed reamer.

Although the accuracy in the operation was of sufficient quality, it was taking a very long time to set the diameter on the tool. If an operator of sufficient skill level was not on site to make diameter changes, the tool could remain idle for hours at a time leading to a reduction in production levels and affecting critical lead times.

#### Smartbore Solution

Rigibore used Smartbore tooling to improve the efficiency of this application. The goals were to provide micron accuracy in adjustment whilst minimising setting time.

PCD inserts were chosen for their wear resistance even when operating at high speeds and feeds. This meant that the tooling could run for longer periods of time without requiring changes to the tool's cutting edge.



#### Results

**Scrap Rates** - The micron accurate adjustment using Smartbore decreased the scrap rate to only 2 parts per 200 from 20 parts per 200.

**Tool Setting** - While tool setting could take an entire shift, the Smartbore tools were accurately set in 30-40 minutes. Smartbore dramatically decreased spindle downtime and maximised production.

**Cost Savings** - The PCD insert replacement cost was about one quarter that of the bladed reamer solution. The results showed that the Smartbore tool machined 4600 parts using just one PCD insert without the need for adjustment.



## Case Studies

### Gear Housing Case Study

#### Project Overview

Smartbore was selected to improve the production output of gear housing components. This second tier automotive component supplier was experiencing problems with accuracy that led to high scrap rates.

The customer was using carbide pads to stabilise the tool and counteract deflection when boring the gear housing components. Rigibore's objectives were to design a tooling package that could operate at a higher speed and feed rate, reducing cycle time and increasing accuracy.

#### Smartbore Solution

Smartbore cartridges allowed simple, micron-accurate adjustment down to 0.001mm on diameter using the Smartbore adjuster.

Hydrostatic tooling used through coolant to efficiently evacuate chips between the bar and component.

Special insert geometry ran at higher surface speeds and lower feeds burnishing to provide a smooth surface finish.



#### Results

**Cp Data** - Smartbore contributes to more efficient process control and parts were now produced within the customer's Cpk requirements.

**Scrap Rate** - Prior to the introduction of Rigibore tooling, 7 out of 100 parts produced were rejected. Rigibore improved this figure with only 1 out of 100 parts being scrapped.

**Surface Finish** - The feed rate was increased from S1800 @ 600mm/min with the old padded style tooling to S6000 @ 1000mm/min with hydrostatic approach.

#### Summary

Rigibore tooling maintained the required surface finish proving that higher surface speeds with lower feed rates reduced the cutting pressure so that there was less deflection.

This coupled with easy micron adjustment outperformed the padded tooling and reduced operating costs.



## Case Studies

### Transfer Case

#### Project overview

To improve machining efficiencies of an aluminium transfer case for a 4 x 4 vehicle. The customer was using brazed PCD fixed pocket tooling. This solution provided superior wear-resistance while operating at high speeds but there were a number of concerns.

**Reconditioning** - the PCD tools produce inconsistent results as they become dull and had to be returned to the manufacturer for reconditioning. Lead times for reconditioning were 10-14 weeks and this led to problems in meeting customer delivery requirements.

The reconditioned tools displayed some **performance inconsistencies**; size, taper and run out differences caused issues with surface finish.

As well as being time consuming, the reconditioning was also **expensive** at about 60-80% of the original tooling cost.

#### Smartbore Solution

Rigibore developed a combination tool that performed the roughing and finishing operation giving exceptional efficiency.

Rigibore used PCD inserts in the tools so that they had the same durability and wear resistance as the previous tools but were simple to replace for wear or damage as opposed to expensive and time-consuming reconditioning,

Adjustment using the hand-held Smartbore Adjuster was simple and the accurate adjustment value clearly displayed on the bright screen.

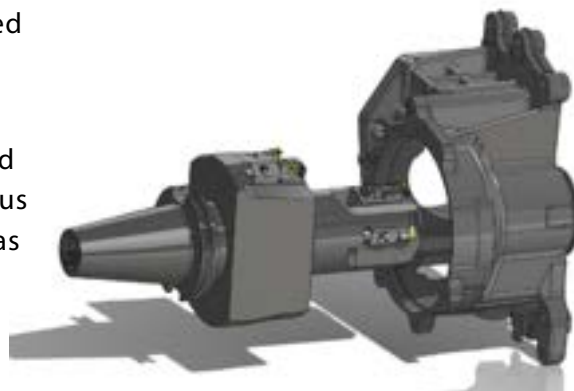

#### Results

**Size Control** - The accuracy of the Smartbore tooling led to much more consistent size control.

**Insert Wear** - When inserts were wearing on the Smartbore tool a simple insert change allowed the operation to continue.

**Ease of Adjustment** - The hand-held digital adjuster allowed micron adjustments to be made by operators of all skill levels.

**Surface Finish** - The introduction of Smartbore tooling reduced the variability in performance and ensured a consistent surface finish.



<https://rigibore.com>

Rigibore Ltd  
Guildford Road Industrial Estate  
Hayle, Cornwall  
TR27 4QZ  
Tel: +44 (0)1736 755355  
Email: info@rigibore.com

Rigibore Inc  
700, Swan Drive  
Mukwonago  
WI 53149  
USA  
Tel: +1 262 363 3922  
Email: info@rigiboreinc.com

Rigibore India Private Ltd  
4/1 Brindavan  
Millers Road  
Bangalore 560052  
India  
Tel: +9180 4125 3035  
Email: info@rigibore-india.com

Rigibore India Private Ltd  
fmTOS,  
Plot No S 13, Pune - Nashik Hwy,  
Tathawade, Sector No. 1, Bhosari, Pune,  
Pimpri-Chinchwad,  
Maharashtra 411039

